

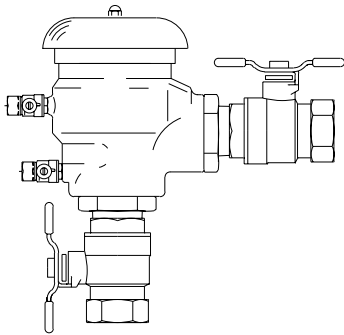

PRESSURE VACUUM BREAKER



INSTALLATION

1. The Pressure Vacuum Breaker Assembly must be installed where it is accessible for periodic testing or repair.
2. The device must not be installed in a pipe line until the line has been flushed of foreign material. Failure to flush the lines completely may cause the check members to become fouled and require disassembly and cleaning.
3. The device must be installed so that the Air Inlet operates in the vertical position (see diagrams). Installation in any other manner will cause the device to malfunction.
4. The device should be installed where some spillage is not objectionable, as instantaneous siphon conditions and pressure surges will cause "spitting."
5. When threading the device in line, place wrench only on ball valve hex ends. Keep pipe dope off interior surfaces of valve.
6. After installation, open inlet ball valve to pressurize device. Slowly open outlet ball valve to fill down-stream line.

NOTE: The downstream pressure must be maintained above 5 psi to keep the spring loaded air inlet poppet closed. If check valve fails to hold 10 psi minimum, it has become fouled and must be cleaned. Close both ball valves and bleed pressure from device before disassembly. Refer to Maintenance Manual for proper service methods.

NOTE: All devices are factory tested for proper operation. Any damage caused by pipe line debris or improper installation is not included in the product warranty. In case of malfunction, or possible warranty claim, DO NOT REMOVE DEVICE FROM LINE. Contact your local Febco Representative.

7. THE DEVICE MUST BE PROTECTED FROM FREEZING. Thermal water expansion and/or water hammer downstream of the backflow preventer can cause excessive pressure increases. Excessive pressure situations should be eliminated to avoid possible damage to the system and device. See recommended freeze protection procedures. (Freeze Protection 765—Technical Sheet FP765)

TYPICAL INSTALLATIONS

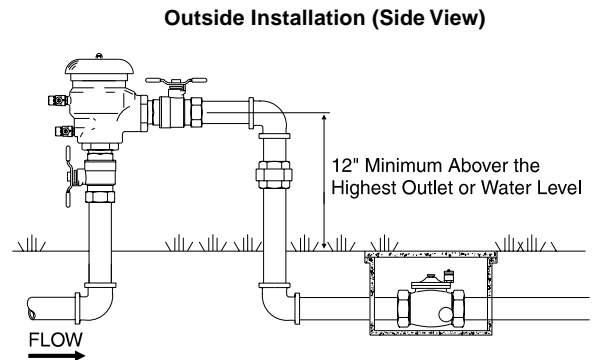

765 - FIELD TESTING PROCEDURE

Equipment Required For Test:

Sight Tube Test Kit (1" clear plastic Sight Tube about 40" long with appropriate fittings to attach to Testcocks of Vacuum Breaker.)

Purpose of Test: (see diagram next page)

To test the Air Inlet and the Check Valves for proper performance.

Test Air Inlet:

The Air Inlet should be tested to verify opening above 1 psi.

1. Remove Canopy from top of Vacuum Breaker to expose Air Inlet.
2. Install Sight Tube at Testcock #2 (as shown).
3. Close Ball Valve B on discharge side of Vacuum Breaker.
4. Open Testcock #2 and fill tube to about 30" above poppet. Close Testcock #2.
5. Close Ball Valve A on Inlet side of Vacuum Breaker.
6. Slowly open Testcock #2 watching poppet in Air Inlet. Poppet must unseat. If the Air Inlet does not open, it is sticking and must be repaired. Close Testcock #2 and remove sight tube.

Test Check Valve:

The Check Valve should be tested to hold against 1 psi in the direction of flow.

1. Install Sight Tube at Testcock #1.
2. Open Ball Valve A to allow unit to refill with water.
3. Open Testcock #1 and allow Sight Tube to fill about 30" above top of unit, then close Testcock.
4. Close Ball Valve A. (Ball Valve B should already be closed.)
5. Open Testcock #1.

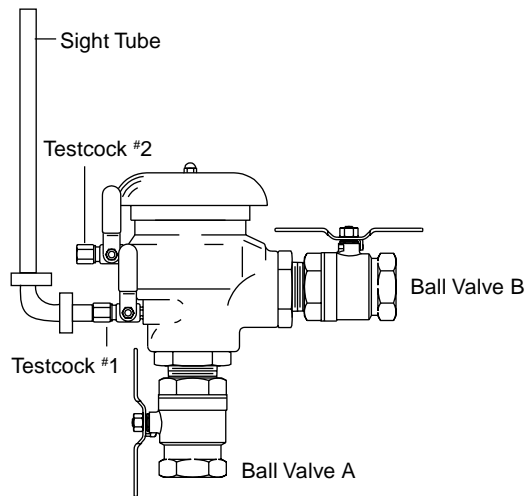

6. Open Testcock #2. Water may run from Testcock #2 initially, but should not continue. The level of water in the Sight Tube may drop a little, but should not drop below 28" above the Check Valve. (Centerline of the Discharge Ball Valve.) If the level in the Sight Tube continues to drop and water continues to run out of Testcock #2, the Check Valve is leaking and should be repaired.

7. Close Testcocks #1 and #2.

Restore Operation:

1. Restore all Valves and Testcocks to their original positions and replace Canopy.

SERVICE PROCEDURE

General service instructions applicable to all sizes.

- a. Rinse all parts with clean water prior to assembly.
- b. DO NOT USE ANY PIPE DOPE, OIL, GREASE OR SOLVENT ON ANY PARTS unless instructed to do so.
- c. Do not force parts. Parts should fit freely together Excess force may cause damage and render the device inoperable.
- d. Carefully inspect seals, seating surfaces, etc. for damage or debris.
- e. Test unit after servicing to insure proper operation.
- f. Tighten canopy nut only until canopy cannot turn freely.
- g. Rapidly open inlet ball valve to minimize spillage through the air vent. Slowly open outlet ball valve.
- h. Test unit to insure proper operation.
- e. Test unit after servicing to insure proper operation.
- f. Refer to applicable parts list and figures for visual aid information.

A. MODEL 765 - 1/2" through 1 1/4" sizes

1. Disassembly Bonnet/Poppet
 - a. Close outlet ball valve then close inlet ball valve. Bleed residual pressure by opening #2 testcock.

- b. Remove canopy nut and canopy.
- c. Unscrew bonnet assembly from valve body by hand (If necessary, use appropriate size wrench on outside diameter of bonnet. However, this may cause damage and require replacement of the bonnet assembly.)

d. Remove poppet/seal assembly from body.

2. Check Valve Removal

- a. Evenly depress retaining bracket approximately 1/4", and rotate bracket 90 degrees.
- b. Remove the bracket, spring and check assembly.

3. Check Valve Seal Replacement

- a. Remove screw holding the guide, and lift the seal from its holder. **CAUTION:** Do not damage the guide legs or the guide pin of the holder.
- b. Insert seal disc into holder, position guide in center of seal and thread the retaining screw through the guide into the holder.
- c. Lightly tighten the screw to hold the guide from rotation. **CAUTION:** Over-tightening may cause distortion of the guide legs.

4. Assembly

To reassemble the device use the reverse procedure described above along with the following special instructions.

- a. Position check assembly into valve body. Position spring into recessed area on top side of check assembly. **NOTE:** In some cases it may be easier to position the spring on the check assembly prior to positioning in the valve body.
- b. When installing the retaining bracket, insure the spring is centered around the base of the bracket .
- c. Roll rubber disc into recess on poppet and position the poppet assembly in the valve body.
- d. To ease assembly of the bonnet into the valve body, apply a thin coating of Vaseline on the o-ring. **DO NOT USE ANY OTHER LUBRICANT.**
- e. Insure the guide pin of the bonnet correctly enters the hole in the poppet.
- f. Thread the bonnet into the valve body by hand until the bonnet flange bottoms on top surface of valve body. **DO NOT OVER-TIGHTEN.**
- g. Tighten canopy nut only until canopy cannot turn freely.
- h. Rapidly open inlet ball valve to minimize spillage through the air vent. Slowly open outlet ball valve.

B. MODEL 765 - 1 1/2" through 2" sizes

1. Disassembly

- a. Close outlet ball valve then close inlet ball valve. Bleed residual pressure by opening #2 testcock.
- b. Remove the six bonnet bolts and lift the bonnet from valve body. Remove poppet and remove seat disc.

- c. To replace poppet spring: unscrew nut, unscrew guide pin and remove spring. Use caution to avoid damage to guide pin. Install new spring and reassemble.
 - d. Remove the spring retaining web, spring and check assembly.
2. Check Valve Seal Replacement
- a. Remove guide retaining nut and guide, lift seal from holder.
 - b. Insert new seal, position guide in center of holder/seal and thread nut to retain guide. Lightly tighten nut to hold the guide from rotating.
3. Assembly
- a. Position the check valve assembly, spring and retaining web into valve body. Insure the arms of the retaining web are aligned with the guide and supports in the valve body.

- b. Roll rubber disc into recess on poppet and position poppet assembly in the retaining web. Place the bonnet on the valve body. Insure the retaining web is properly supported by the three case bosses inside the bonnet.
- c. Insert the bonnet bolts and tighten.
- d. Rapidly open inlet ball valve to minimize spillage in the air vent. Slowly open outlet ball valve.
- e. Test unit to insure proper operation.

PRESSURE VACUUM BREAKER - MODEL 765

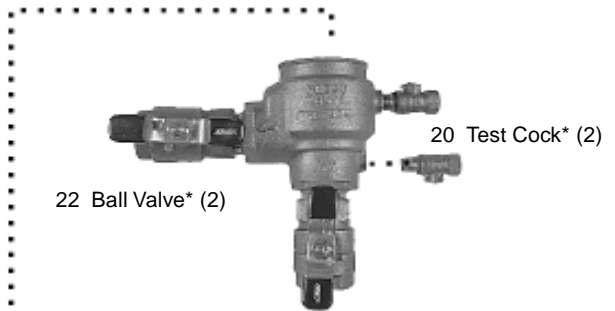
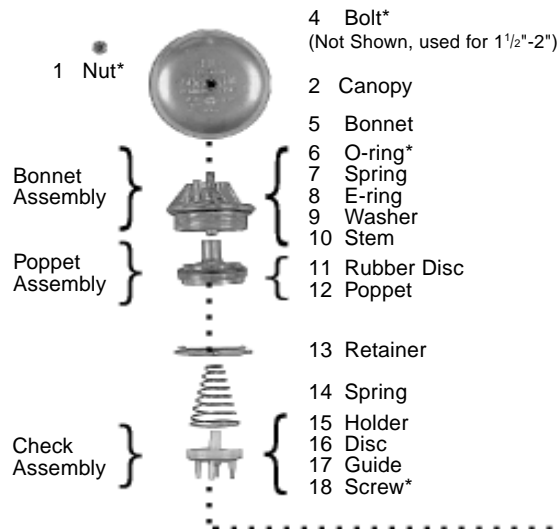

Illustration shown is for sizes 3/4" through 1 1/4" only.
Bonnet and bolt for 1 1/2" and 2" not shown.

* COMMERCIAL PARTS

Fig. No.	Description	Quantity	765 1/2"	765 3/4"	765 1"	765 1 1/4"	765 1 1/2"	765 2"
1	Nut		523-533-00	523-533-00	523-543-00	523-543-00	523-543-00	523-543-00
2	Canopy		300-092	300-093	300-089	300-089	300-094	300-083
4	Bolt	6	-	-	-	-	511-514-06	511-514-06
6	O-Ring		398-026-72	398-026-72	398-140-72	398-140-72	398-247-72	398-247-72
7	Spring		-	-	-	-	630-096	630-096
10	Stem		-	-	-	-	200-767	200-767
13	Retainer		300-096	300-096	300-088	300-088	-	-
14	Spring		630-108	630-108	630-106	630-106	630-063	630-063
20	Test Cock	2	781-074	781-074	781-075	781-075	781-075	781-075
22	Ball Valve	2	781-047	781-048	781-049	781-050	781-051	781-052
Part Kits								
	Rubber Parts Kit (6, 11, 16)		905-020	905-020	905-021	905-021	905-022	905-022
	Bonnet Assembly (5-10)		905-047	905-047	905-048 ⁽²⁾	905-048 ⁽²⁾	-	-
	Bonnet/Kit (3, 5-10)		-	-	-	-	901-857	901-857
	Poppet Assembly (11,12)		905-049	905-049	905-050	905-050	901-860	901-860
	Check Assembly (15-18)		905-051	905-051	905-052	905-052	-	-
	Check Repair Kit (6, 13, 15-18)		-	-	-	-	905-070	905-070
	Bonnet/Poppet Kit (5-12)		905-211	905-211	905-212⁽²⁾	905-212⁽²⁾	-	-

(2) Kit includes parts to retrofit older style units

most common
repair parts

TROUBLE SHOOTING GUIDE

SYMPTOM	CAUSE:	SOLUTION:
1. Check valve fails to hold 1.0 PSID minimum	A. Debris on sealing surface or guide surfaces valve surfaces	Disassemble and clean check
	B. Damaged seat disc	Disassemble and replace seal
	C. Weak or broken spring	Disassemble and replace spring
	D. Poppet broken due to thermal expansion	Replace broken poppet (see freeze protection)
2. Poppet fails to open at 1.0 PSIG minimum	A. Debris restricting free operation	Disassemble and clean check valve surfaces
	B. Poppet seal adhering to bonnet	Disassemble and clean and/or replace damaged parts
	C. Weak spring load	Replace bonnet assembly (1/2 - 1/4) Replace spring (1 1/2 and larger)
3. Minor leakage through air vent	A. Damaged poppet seal	Disassemble and replace seal
	B. Cracked or damaged poppet	Disassemble and replace poppet seal
	C. Cracked bonnet or damaged sealing edge	Disassemble and replace bonnet assembly
	D. Debris on sealing surface	Disassemble and clean
4. Significant discharge through air vent	A. Poppet not properly guided	Disassemble and replace damaged parts
	B. Major poppet or seal failure	Disassemble and replace damaged parts
	C. Low downstream pressure	Check pressure at #2 testcock; should be higher than 5 PSIG if low system
	D. Insufficient inlet volume to operate device	Pressure needs to be increased or partially closed outlet ball valve to create higher pressure on poppet.
	E. Poppet and or bonnet broken	Replace broken bonnet/poppet due to thermal expansion (see freeze protection)
5. Chatter during flow conditions	A. Worn, damaged or defective check valve guide	Disassemble and repair or replace guide

www.watermeters.com
www.jerman.com
www.dljmeter.com
www.oilmeters.com
www.backflowpreventers.com
www.fire-sprinkler.com

Daniel L. Jerman Co., 275 Railroad Place, Hackensack, NJ 07601
 800.654.3733 201.487.7444 Fax 201-487-3953

We can ship your order via UPS the same day we receive it. We accept visa/mastercard/discover, PAYPAL online paying to jonjerman@aol.com, COD UPS (\$7.00 additional), open account after credit approval, or you can send a check with your order. You can fax, e-mail, regular mail or phone in your order. Our handle on www.ebay.com is "jond8" if you would like to see what our customers say about our products and service. Thanks again for your inquiry. Unlike many internet firms we welcome your call at 800-654-3733 if you have any questions or wish to place an order over the phone.