

# Specification Sheet

# Industrial Turbine Meter

Model T3000 Bronze, Magnetic Drive, Round Flanged Ends



**T3000 CB**  
All Sizes

**T3000CP**  
4" Only  
(not shown)

## Description

**Operation.** T3000 Turbine Meters are designed for installation where occasional low and moderate to high sustained flows are expected. Water passes through the meter without a change in flow direction, driving a helix rotor in direct proportion to the quantity of water passing through the meter. Rotor revolutions are transferred to a register by appropriate reduction gearing and a magnetic drive.

**Compliance to Standards.** The T3000 Turbine Meter complies with all performance and material requirements of the American Water Works Association Standard C701, Class II In-Line (High-Velocity) Type, as most recently revised.

**Installation.** The meter must be installed in a clean pipeline, free from any foreign materials. Install the meter with direction of flow as indicated by the arrow cast in the meter case. The meter may be installed in horizontal, inclined or vertical lines. It is recommended that a plate strainer be used to protect the measuring element and help reduce the effects of turbulence. The installer should consider a bypass pipe with gate valves for use during maintenance and a downstream test plug for future field testing.

**Application.** T3000 meters are for use in POTABLE COLD WATER up to 120°F (50°C) and working pressures up to 150 psi. The meter will perform with accuracy registration of 100% ± 1 1/2% within the normal flows\*. Both pressure loss and accuracy tests are made before shipment. No adjustments need be made before installation.

**Construction.** The meter consists of a main case, a measuring element, a case cover and a magnetically driven register assembly. The main case is cast in bronze with raised characters showing model, size and direction of flow. The case has a throated inlet. A case dowel pin is inserted for locating the cover plate. The measuring element assembly consists of the rotor, straightening vanes, accuracy regulator, spindles and gears, filters and undergear assembly. The measuring element is attached to the underside of the cover with four stainless steel screws and washers, one insert of which is placed eccentrically in the cover. The internal regulator assembly is interconnected with an external regulator shaft located

## Specifications

	4"	6"	8"
<b>Performance</b>			
95% - 101% Accuracy GPM	7	15	25
*98.5%-101.5% Accuracy GPM	10-1250	20-2500	30-3500
Continuous Flow GPM	1000	2000	2800
Maximum Flow GPM	1250	2500	3500
Operating Pressure psi	150	150	150
Operating Temperature°F	120	120	120
<b>Sweep Hand Registers</b>			
US Gallons	100	1000	1000
Cubic Feet	10	100	100
Cubic Meters	1	10	10
Imperial Gallons	100	1000	1000
<b>Capacity of Register</b>			
US Gallons (millions)	100	1000	1000
Cubic Feet (millions)	10	100	100
Cubic Meters (millions)	1	10	10
Imperial Gallons (millions)	100	1000	1000
<b>Register Type</b>	Permanently sealed direct reading register.		
<b>Materials</b>			
Main Case	Bronze		
Top Cover Plate	Bronze or Polymer (4" only)		
Body O-Ring	Neoprene Rubber		
Case Bolts	Stainless Steel		
Measuring Element	Polyphenylene Oxide		
Rotor	Polypropylene		
Rotor Bushings	PTFE Compound		
Rotor Thrust Bearing	Ceramic Jewel		
Rotor Spindle	Tungsten Carbide		
Undergearing	Polyacetal Resin		
Register Lens	Tempered Glass		
Register Housing and Lid	Polymer or Bronze		
Register Can	90% Copper Alloy		

Note: For bronze meters with bronze top plates, bronze top would be machined to accept LRP/HRP.

on top of the cover allowing meter calibration without depressurizing the test bench or meter service. The regulator is protected by a tamperproof device. The main case and cover are assembled with an O-ring gasket and stainless steel bolts. The register assembly is secured to the cover with a slotted screw and is hinged over the inlet throat. However, the register can be rotated and locked in any 360 degree position therein.

**Register.** The register is contained within a 90% copper seamless can which is oven cured at 150°F for 90 minutes to eliminate condensation. The 1/4" true tempered glass lens is domed and secured in an "L" shaped gasket, then roll sealed. To assure easy reading, the totalizer wheels are large and color coded. The applicable size, model, registration, part number and date code are printed on the calibrated dial face. Moving clockwise during operation, the extra thin sweep hand does not interfere with meter reading, and the flow indicator will detect plumbing leaks.

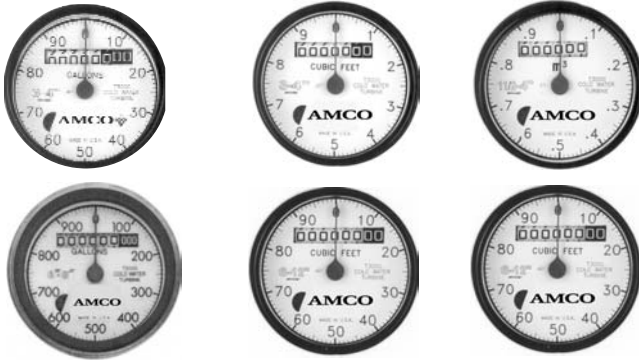

**Magnetic Drive.** The magnetic drive design eliminates miscoupling associated with right angle drives. Torque is absorbed in the undergear assembly below the driving magnet. Consequently, the driving magnet at all flows is turning slowly, assuring magnetic coupling with the register assembly. The undergearing is protected by an appropriately filtered encasement.

**Connections.** These meters are available with eight-bolt round flanged end connections. Round flanged connections conform to ANSI B16.1 cast-iron pipe flange, Class 125. Both bronze and cast-iron companion flanges are available. The companion flanges are faced, drilled and tapped with ANSI B2.1 internal taper pipe thread and conform to ANSI B16.1 cast-iron pipe flange, Class 125.

**Maintenance.** The measuring element with integral straightening vanes can be removed, repaired or replaced without removing the main case from the service line. Blank cover plates are available for use during repair. Pretested and calibrated measuring elements with cover plates and registers are available for exchange or purchase from our warehouses in the U.S. and Canada. In addition, AMCO Water Metering Systems maintains a fully equipped and staffed repair facility in Ocala, Florida.

**Pulsers.** See Specification Sheet #LRP/HRP-T3000.  
LRP (2-wire) Reed Switch, 4 Watt (50V AC/DC Max.)  
HRP (3-wire) Slotted Disc, 6-15 VDC  
Both units require power from an external source.

**Dimensions and Net Weights**

Meter Size	Dimensions (inches)					Weight (lbs.)
	A	B	C	D	E	
4"	14	10 3/4	4 3/16	8 3/16	9	51 1/2
6"	18	13 3/8	5 1/4	10 15/16	11	90
8"	20	16 1/16	6 15/16	11 7/16	13 7/16	168

Note: Add 3/4" to overall height with polymer top plate (4").

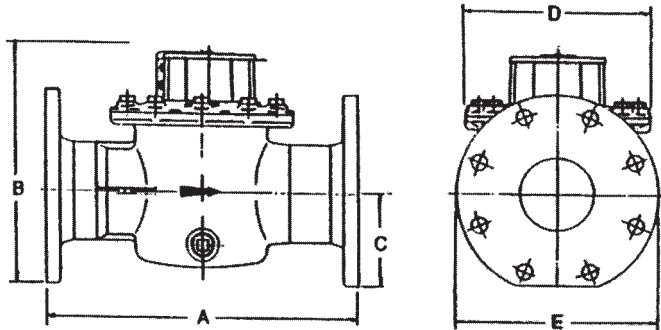

**AMCO**   
Distributed by:

[www.watermeters.com](http://www.watermeters.com)

**Daniel L. Jerman Co.**  
275 Railroad Place  
Hackensack, NJ 07601  
Phone 800.654.3733  
Fax 201.487.3953  
International Phone  
201.487.7444

IND-T3- BZ--48/02-03